

Accessory kit



Item	Qty	Description
1	2	Dead center (1 short, 1 long)
2	1	Allen wrench set (4 keys)
3	1	8-10mm Wrench
4	1	12-14mm wrench
5	1	CNC Base Control Software
6	2	Electrical panel keys
7	1	5x20 mm fuse - 10 Amp
8	1	Chuck key, T-handle
9	3	Chuck jaws
10	1	Ethernet Cable

BenchTurn 7000

Turning Center



Technical Support:

Phone (800) 221-2763
 Fax (603) 625-2137
 Email support@intelitek.com
 Web www.intelitek.com

Before contacting Intelitek make sure you have the following information:

- The product serial number
- The name of the owner of the product
- Your computer specifications / documentation
- Notes on any control program error messages
- Access to the hardware and software components of your system

34-0000-7000 Rev-B



444 East Industrial Park Dr. • Manchester, NH 03109
 Phone: 800-221-2763 • info@intelitek.com
 www.intelitek.com

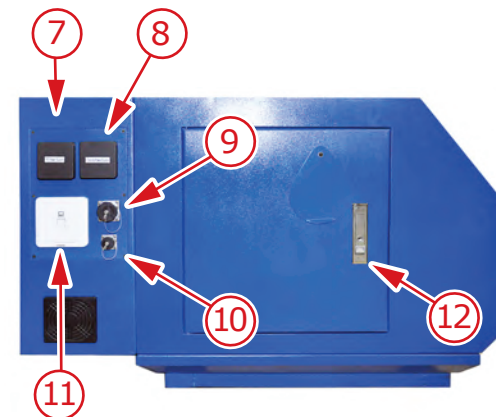

Left side panel

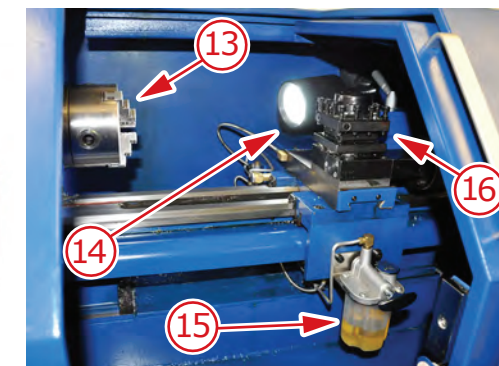

Enclosure view

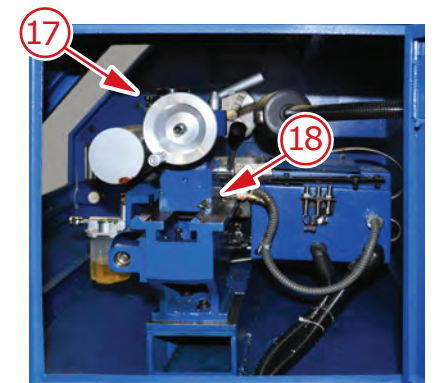

Right side enclosure view

Machine components

Item #	Description	Item #	Description
1	Enclosure door	10	Fanuc panel port
2	Emergency stop switch	11	Ethernet port
3	Enclosure release button	12	Left side access door
4	I/O Ports	13	Chuck
5	On/Off switch	14	Work light
6	Right side access door	15	Lubricant reservoir
7	PC power supply	16	Tool turret
8	Coolant power supply	17	Tailstock
9	Jog pendant port	18	Serial number (top of rear rail)



Step 1

Unpack the Machine

- 1 Remove the crating:

CAUTION

Hold the crate components securely when removing them so that they do not strike or damage the machine.

- Cut any banding on the outside of the crate.
- Remove the top of the crate.
- Remove the sides of the crate.

- 2 Remove the 4 shipping bolts that hold the machine to the pallet.



400 lbs (180 kg)



CAUTION

Lifting hazard!

Machine weighs approximately 400 lbs (180 kg). Failure to lift properly may result in injury.

If possible, use mechanical means, such as a forklift, to lift the machine. If no mechanical lift is available use four people to lift the machine. Use proper lifting techniques.

- 3 Lift the machine off the pallet onto the workbench.

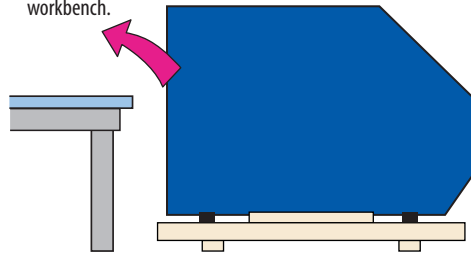

To lift manually:

- 1 Position the machine table or workbench next to the machine.
- 2 Turn the 4 lift handles out.
- 3 With one person on each corner of the machine, carefully lift the machine by the lift handles onto the workbench.
- 4 Spin the 4 handles back underneath the enclosure.

- 4 Open the front door and remove the components from the enclosure.

Step 2

Connect the Machine

- 1 **Connect to power:** Plug the power cord on the left side of the machine into your facility electrical power.

- 2 (Optional) **Connect to air:**

CAUTION

Avoid injury or damage to equipment!

Turn off the supply of pressurized air at the source, or at a shutoff valve between the source and the machine before connecting the air lines to the machine.

If your machine includes optional pneumatic equipment, connect your facility air supply to the pneumatic regulator. See the documentation for your specific options for more details.

NOTE:

The method for connecting pressurized air may vary depending on your facility. Consult the appropriate facility personnel if you are unsure how to connect your machine to your air supply.

- 3 **Connect to Ethernet:** Connect one end of the provided Ethernet cable to your computer's Ethernet port. Connect the other end to the CNC machine's Ethernet port.

CAUTION

Avoid damage to equipment!

Do not connect the CNC machine to the Ethernet through a router or network switch. Connect the machine directly to the computer's Ethernet port.

Step 3

Install the Software

Install the software:

- 1 Insert the installation CD into the computer's CD drive.
- 2 Select Start > Computer and navigate to the Install folder on the CD drive.
- 3 Double click on the iCNC.exe file to start the installation.
- 4 When prompted, select the appropriate machine from the list.

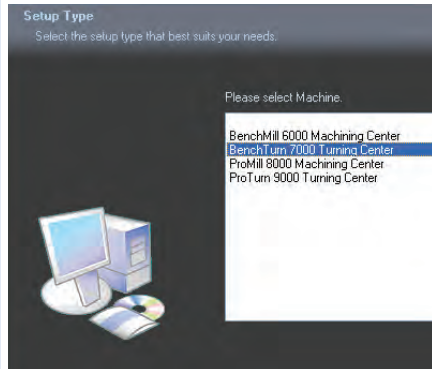

- 5 Follow the on-screen instructions.

- 6 Restart your computer.

Step 4

Configure the IP Address

NOTE:

You must have administrator access to your computer to run the Machine IP Changer utility.

- 1 Run the Machine IP Configuration utility:

From the desktop, click Start > CNC Base for Intelitek CNC > Machine IP Configuration.

- 2 From the dropdown list, select the local area network or network card that you wish to use for the CNC machine then click Continue.

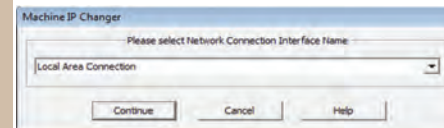

- 3 When prompted, click Yes to confirm the IP setting. The utility automatically changes your IP address to a static one, allowing iCNC to communicate with the machine.

When the process is finished, Machine IP Changer displays the configuration for all active network connections.

- 4 Press OK to complete the IP address configuration.

Step 5

Install the Tool



WARNING

Rotating shaft!
Moving cutting tools!
Handle cutting tools carefully.



Before opening the safety shield:

- Press the Emergency Stop button.
- Wait until all motion has stopped.

Tool turret diagram

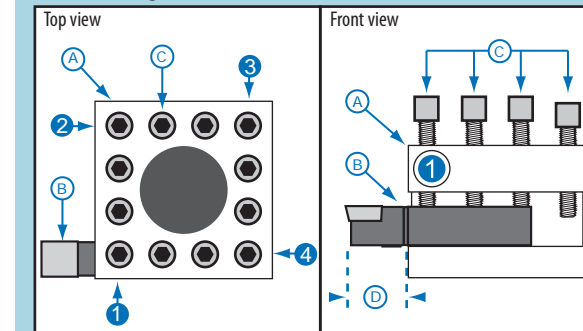

Item #	Description
A	Tool turret plate
B	Tool
C	Turret screws
D	1.125" (28mm) max dimension
1	Tool position marker

NOTE:

The tool turret will support up to 4 tools at one time. The tool positions are numbered on the side of the tooling plate.

- Mount tools in these positions with the cutting tip face up.
- The tool tip must not extend more than 1.125" (28mm) from the tooling plate to avoid tool chatter.
- Use a minimum of two screws to secure the tool.
- To achieve tight machine tolerances and surface finish, the tool tip and spindle centerline must lie on the same plane. If necessary, use shims to mount tools in the turret.

Install the tool in the tool turret:

- 1 Push in the emergency stop button and open the enclosure door.
- 2 If a tool is currently present:
 - Loosen the turret screws holding the tool using the 6mm Allen wrench.
 - Remove the tool and shim (if a shim is present).
- 3 Insert the tool with the cutting tip face up into the turret. Add shims if necessary to align the tool to the spindle centerline.
- 4 Tighten the turret screws. Be sure to use a minimum of two screws to secure the tool.
- 5 Close the enclosure and release the emergency stop button.

CAUTION

Avoid damage to equipment!

Before cutting, make sure that each tool has sufficient clearance so it does not strike the chuck or workpiece when changing tools.